

# MODULAR

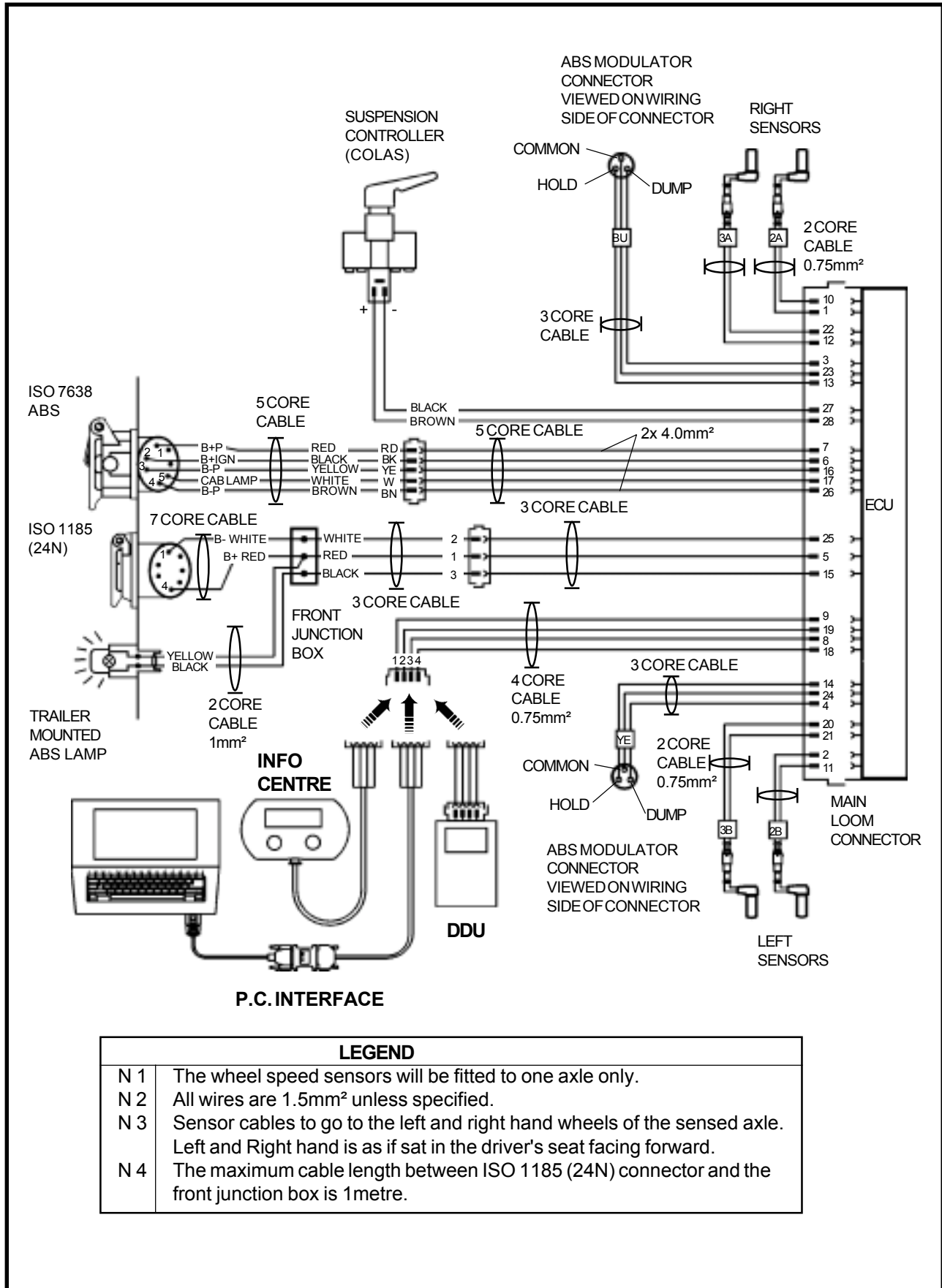

LEGEND	
N 1	The wheel speed sensors will be fitted to one axle only.
N 2	All wires are 1.5mm <sup>2</sup> unless specified.
N 3	Sensor cables to go to the left and right hand wheels of the sensed axle. Left and Right hand is as if sat in the driver's seat facing forward.
N 4	The maximum cable length between ISO 1185 (24N) connector and the front junction box is 1metre.

Fig 12.11 MODULAR 2 -4S/2M WIRING DIAGRAM ISO 7638 (UNFUSED) AND ISO 1185 (24N) POWER SUPPLY