

LEGEND

N1	SENSORS 3A AND 3B ARE OMITTED IN 2S INSTALLATIONS.
N2	SOME MODULATORS HAVE THE CABLE AS A FLYING LEAD i.e. THERE IS NO IN LINE CONNECTOR FITTED.
N3	ALL WIRES ARE 1.5mm ² UNLESS SPECIFIED.
N4	DIAGNOSTIC WIRING INSTALLED HALDEX OMITTED FOR CLARITY.
N5	SENSOR PAIR 3A, 3B MAY BE FITTED TO A LIFT AXLE.
N6	AXLE 3 IS AT THE FRONT OF THE BOGIE.
N7	SENSOR CABLES TO GO TO THE LEFT AND RIGHT HAND WHEELS OF THE SENSED AXLE. LEFT AND RIGHT HAND IS AS IF SAT IN THE DRIVER'S SEAT FACING FORWARD.
N8	THE MAXIMUM CABLE LENGTH BETWEEN ISO1185 AND ISO3731 CONNECTORS AND THE FRONT JUNCTION BOX IS 1METRE.
N9	ALL CABLES EXCEPT MODULATOR AND SENSOR CABLES ARE TO BE ENCLOSED IN CONDUIT.
N10	SENSOR CONNECTOR.
N11	FOR SEMI-TRAILER CONFIGURATION REFER TO SECTION 8.

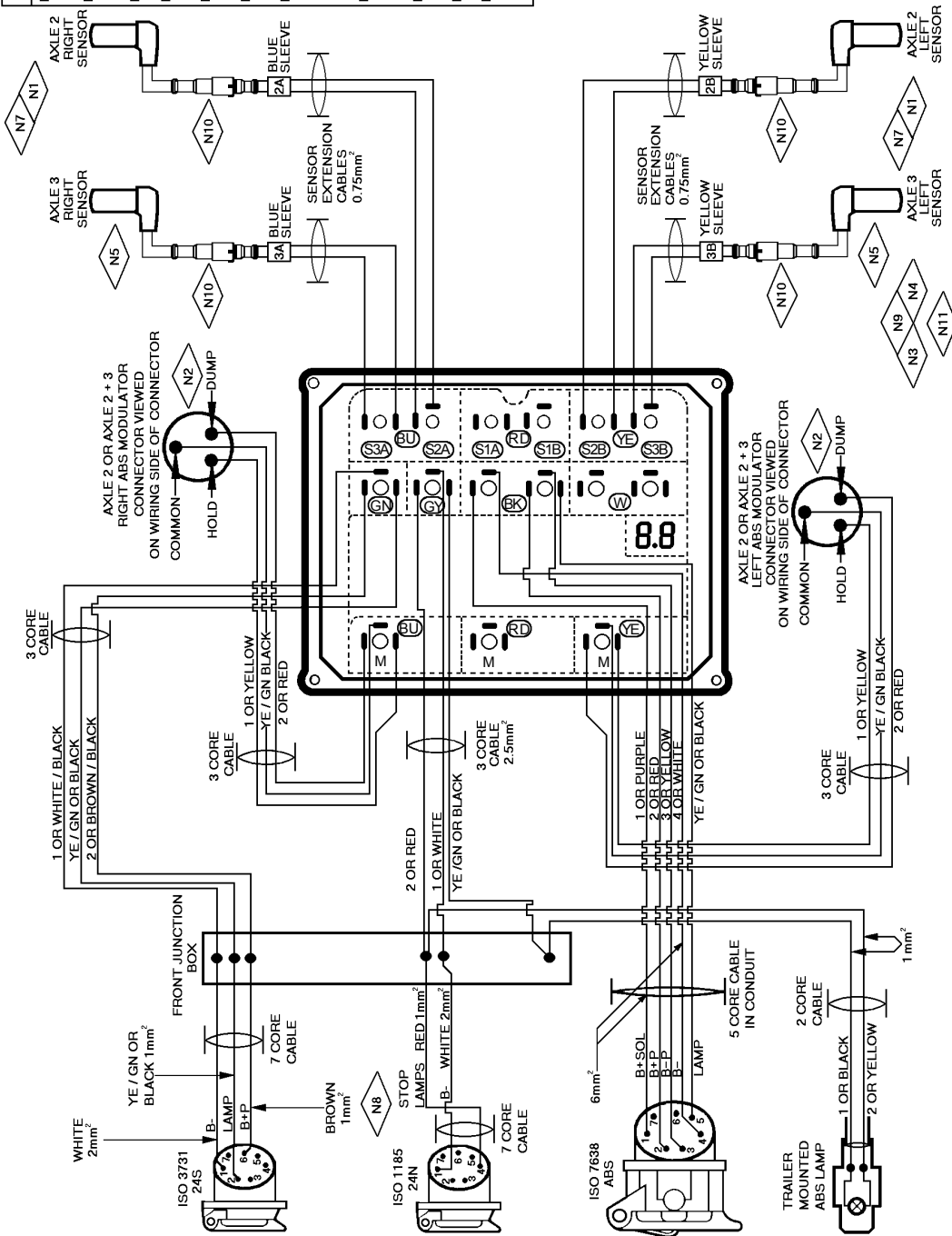

Fig 11.6 MODAL SEMI TRAILER WIRING WITH TWO OR FOUR SENSORS AND TWO MODULATORS (2S2M OR 4S2M) FOR HAZARDOUS LOAD CARRIERS