

LEGEND	
N1	SENSORS 3A AND 3B ARE OMITTED IN 4S INSTALLATIONS.
N2	SOME MODULATORS HAVE THE CABLE AS A FLYING LEAD I.e. NO CONNECTOR IS FITTED.
N3	ALL WIRES ARE 1.5mm ² UNLESS SPECIFIED.
N4	DIAGNOSTIC WIRING INSTALLED BY HALDEX IS OMITTED FOR CLARITY
N5	SENSOR PAIR 3A, 3B MAY BE INSTALLED ON A LIFT AXLE.
N6	AXLE 1 IS AT THE FRONT OF THE VEHICLE.
N7	SENSOR CABLES TO GO TO THE LEFT AND RIGHT HAND WHEELS OF THE SENSED AXLE, LEFT AND RIGHT HAND IS AS IF SITTING IN THE DRIVER'S SEAT FACING FORWARD.
N8	THE MAXIMUM CABLE LENGTH BETWEEN THE ISO3731 CONNECTOR AND THE FRONT JUNCTION BOX IS 1m.
N9	SENSOR CONNECTOR.
N10	FOR FULL TRAILER CONFIGURATION SEE SECTION 8.0.
N11	ON HAZARDOUS LOAD CARRIERS ALL CABLES EXCEPT MODULATOR AND SENSOR CABLES ARE TO BE ENCLOSED IN CONDUIT.

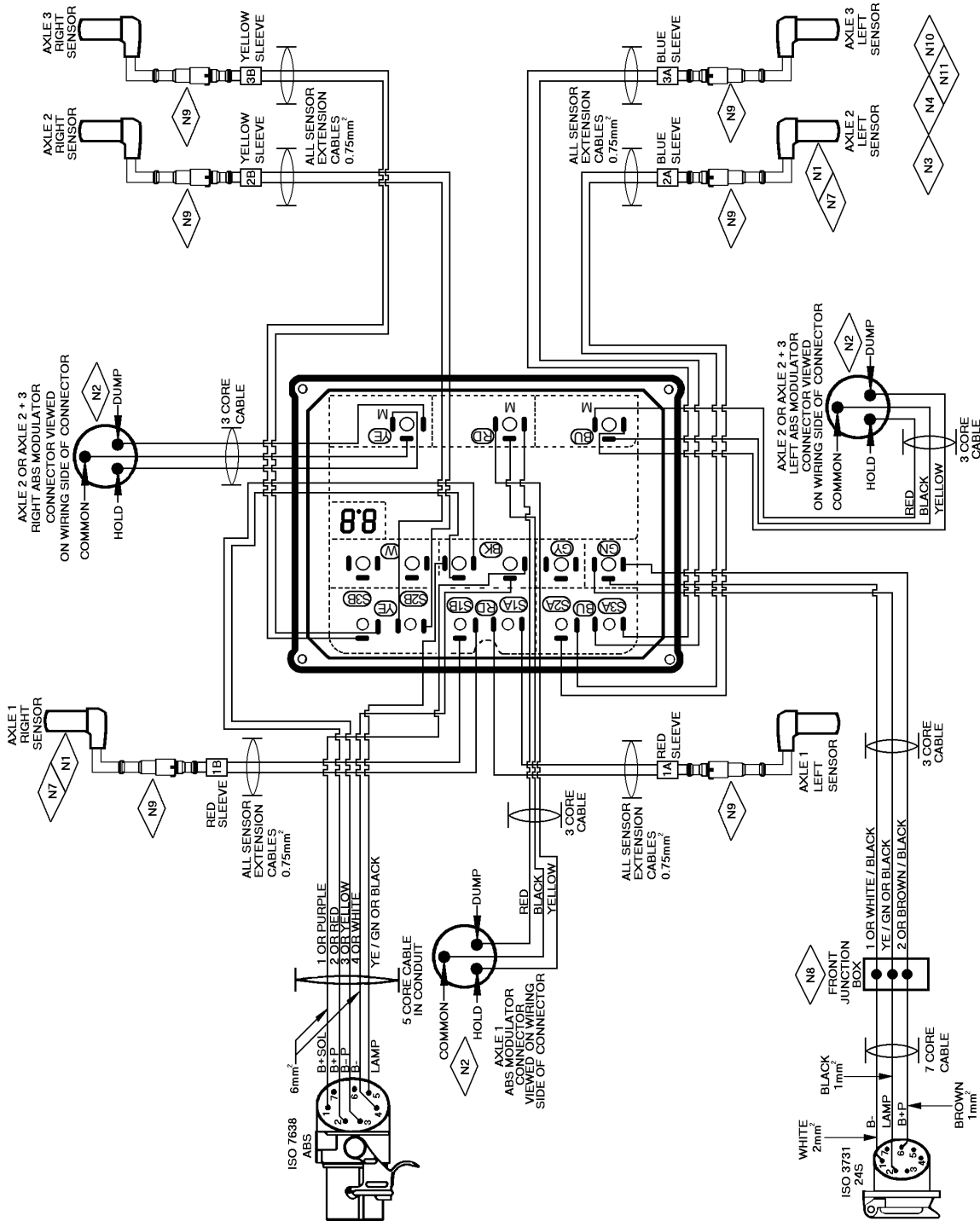

Fig 11.8 MODAL FULL TRAILER WIRING WITH FOUR OR SIX SENSORS AND THREE MODULATORS (4S3M OR 6S3M)